

Guardex



Guardex

Flap barrier GRD-TF441



GRD-TF441 is an upgrade version special design for construction plant. With its unique design, it can entirely solve the bottleneck of normal turnstile, make the turnstile become an effective tool for construction plant access control. Moreover, we optimize the mechanical structure and material, all turnstiles use bulletproof PC material for barrier and card reader cover, it has higher fatigue resistance and impact resistance. The robust SUS body, anti-corrosive surface and waterproof design guaranteed the reliable operation of GRD-TF441 under the extreme outdoor conditions.

OPERATING MODES

- Single passage in the set direction
- Bi-directional single passage
- Free passage in the set direction
- Always free or locked

MATERIALS

- Housing: Made in stainless steel AISI 304 or AISI316
- Barrier swings-Acrylic, PC, stainless steel frame

FEATURES AND BENEFITS

- Quiet, low-noise operation.
- Rests in a low-energy, "sleep" mode and activates upon approach.
- Modular design that allows to integrate different types of

external equipment: bar-code scanners, biometric readers, card readers, coin collector and card collectors, etc.

- Power by adapter, easy for installation and after service.
- Power module installed in a protect box to prevent humidity and dust, increase the lifespan and working performance to its Maximum.
- Equipped with double protection design, including IR sensors anti-clamping, and mechanical anti-clamping. It can sensitively detect users' passing status so as to prevent hitting users, meanwhile, prevent illegal intrusion and tail-gating pass.
- The turnstile top cover flashing LED direction indicators with bright pictograms displaying a status of the turnstile, indicating authorized/ not authorized and passage direction.
- Module design LED panel, make the installation and after service convenience.
- Automatic reset function. If a passer does not pass the way during required time, the system will automatically cancel his right of pass.
- Automatic "Anti-panic" barrier enable immediate clear the passageway in emergency situations without use of any special keys or tools.
- Automatic reset function. If a passer does not pass the way during required time, the system will automatically cancel his right of pass

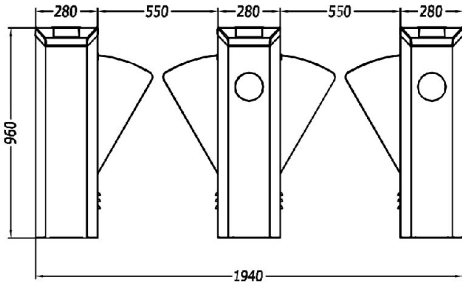
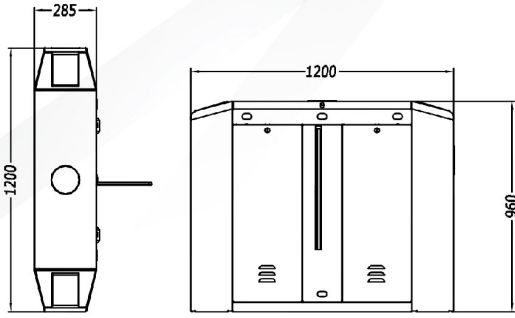

Technical Data	Unit	GRD-TF441
Passage width	mm	≤550
Throughput rate	p/m	35
Power supply	V/(ac)	100-240
Operational voltage	V/(dc)	24
Max power consumption	w	20
Frequency	hz	50-60
Protection level	IP	>44
Working temperature	degree	-25 to +70
Dimension excluding bars	mm	1200*280*960
Net weight including bars	Kg	80

Project Cases

